

# **Omni Block**

AN INSULATED CONCRETE BLOCK



## *Construction Manual*

*building with the best*



## DISCLAIMER

The information presented in this manual is to assist professional builders, architects, designers, and engineers in the understanding of the Omni Block Insulated Concrete Block System. While the material is presented in good faith and believed to be reliable, it does not constitute a part of, or terms and conditions of sale. No engineering data, design information or other material contained herein shall be deemed to constitute a warranty, expressed or implied, that said information is correct or that the products described are fit for a particular purpose or design application.

## PREVAILING CODE

The information presented in this manual is not intended to supersede any local, regional, national, or international building codes. All information should be examined individually and wholly to determine whether the procedural suggestions contained herein comply with the prevailing building code.

This publication is copyrighted © 2001, © 2007, © 2012 and © 2015  
All rights reserved. Version 3.3



## CORPORATE OFFICE

5940 S Rainbow Boulevard • Las Vegas NV 89118 • 877-711-OMNI (6664)  
[www.omniblock.com](http://www.omniblock.com) • [info@omniblock.com](mailto:info@omniblock.com)

This Field Guide manual has been created to provide the professional builder procedural recommendations for constructing buildings utilizing Omni Block.

This manual assumes:

- 1) that you are familiar with masonry construction techniques and terminology,
- 2) that you are a professional general contractor or supervisor,
- 3) that you are utilizing a qualified mason,
- 4) that you are interested in an efficient construction process.

The recommendations that follow should be adhered to whenever possible. Omni Block is a system made up of individual components. A successful system requires that the components are implemented at the proper time.

Omni Block, when properly installed, saves future scheduling time because one subcontractor (the mason) accomplishes the work of several other subcontractors. When proper planning is performed by the general contractor the system makes sense, saves you construction cost, goes smoothly, and assures you a quality product.

Legal Disclaimer	2
Masonry	
Footings	4
Concrete Stem	4
Block Stem	4
Shop Drawing	5
Rebar Placement - Plan View	5
Rebar Placement - 8" Isometric View	6
Rebar Placement - 12" Isometric View	6
Plumbing	
Water Main Riser	7
Water Lines	7
Hose Bibbs	8
Waste Vents	8
Dirty Arms	8
Access Panels	8
Fire Sprinkler Systems	9
Hot Water Pressure Relief	9
Gas Piping	9
HVAC	
HVAC Piping Sleeves	10
Dryer Vent	10

Electrical	
Ufer Wire	11
Low Voltage	11
Electrical Service Riser	11
Electrical Chase	11
Meter Main Panel or Box	12
Electrical Box Placement - Interior	12
Sound Wiring	12
Security Wiring	12
Door Bell Wiring	12
Electrical Box Placement - Exterior	13
Thermostat Wiring	13
Air Conditioning 220 Volt Wiring	13
Garage Electric Eye Wiring	13
Electrical Parts List	13
Windows and Doors	
Dimensions / Sizing	14
Aluminum or Vinyl Windows / Doors	14
Wood Windows / Doors	14
Wood Window / Door Buck Options	14
Window / Door Jamb Detail	14
Framing	
Lintel Detail	15
Top Plate	15
Bond Beam	16
Trusses	16
Trusses / Parapet Tails	16
Ledger	16
Beam Seats	17
Interior Partition Walls	17
Interior Finishes	
Drywall Appearance	18
Top Plate Coverage	18
Corner Bead	18
Paint	18
Repairs	18
Exposed Block	18
Sealers	18
Stains	18
Exterior Finishes	
Exposed Block	19
Sealers	19
Stains	19
Paint	19
Stucco	19
Integral Synthetic Stucco	19
Surface Bond (Optional)	
Material	19
Preparation	19
Application	20
Curing Recommendations	20
Start-up Coordination Sheet	21
Flowchart	22

Please be advised that it is to your advantage to read this entire Field Guide before beginning construction to save costs and time.

## Components

The 8" system has four block components; stretcher, right corner, left corner, and standard half block. The corner block is also the jamb block.

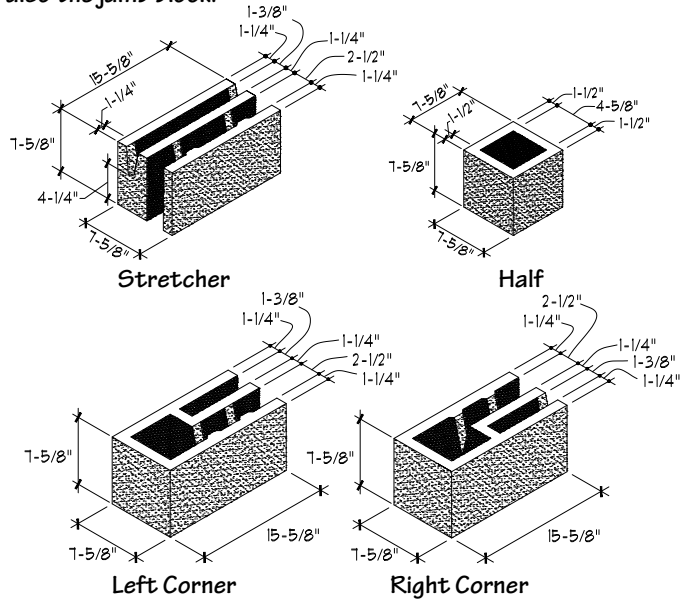

The 12" system has three block components; stretcher, corner, and standard half block. The corner block is also the jamb block.

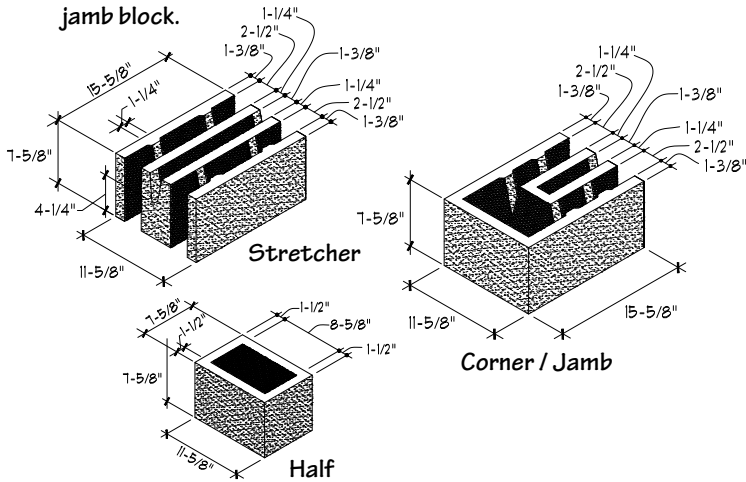

Both the 8" and 12" systems use the same foam inserts.

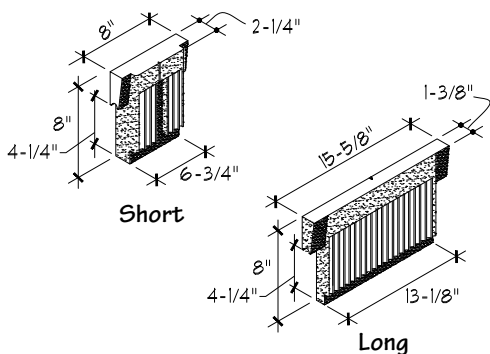

## Footings

Typical concrete construction methods should be followed for installing the footings when utilizing Omni Block. See building's approved engineered plan set for rebar and concrete psi requirements.

## Stem Walls

Requirements:

- 1) Rebar sizing, schedule and frequency per engineering (see plan set details or engineer supplied drawings).
- 2) In the event that a shop drawing is not available, place all vertical rebar per Figure 3.
- 3) Minimum overlap; 40 bar diameters.
- 4) 8" wide.

Figure 1

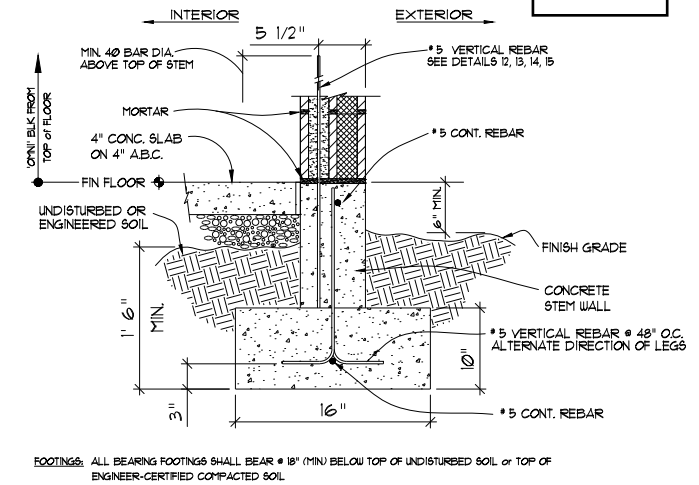

OPTION A - CONCRETE STEM

Figure 2

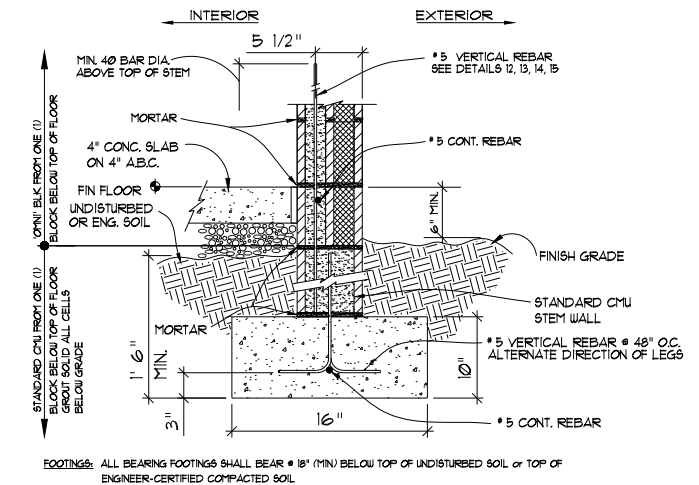

OPTION B - BLOCK STEM

## Block Stem Wall Advantages

Omni Block recommends installing standard CMU block for the lower courses and installing Omni Block for the top course.

- 1) Correct rebar placement is facilitated because grout cells are clearly defined.
- 2) Block stem is more level than a poured-in-place concrete stem.
- 3) No 'overhangs' or misalignment from block stem-to-block wall transition will occur above finished floor.
- 4) Insulation is placed in exterior cell (see Thermal Analysis for specific R-value information).
- 5) Areas where plumbing and electrical stub up into stem, the block can be left void of grout, which minimizes the need to cut or hammer into the stem (see Plumbing and Electrical sections).

## Shop Drawings

Omni Block recommends that a 'shop drawing' defining the exact rebar location be provided to the concrete and/or masonry subcontractor by either the architect, designer, or structural engineer of record.

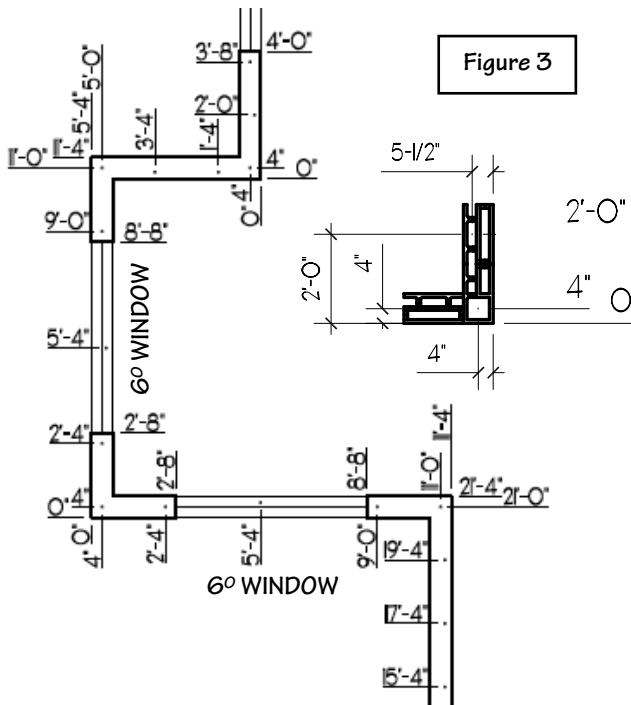
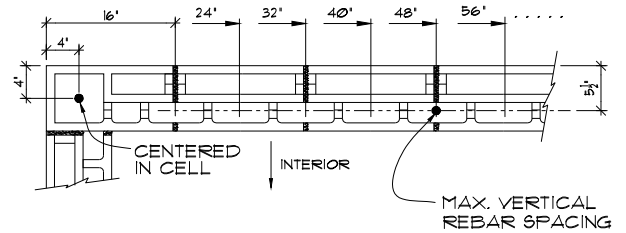

Figure 3

SHOP DRAWING EXAMPLE

## Rebar Placement

Figure 4



STANDARD WALL - 8"

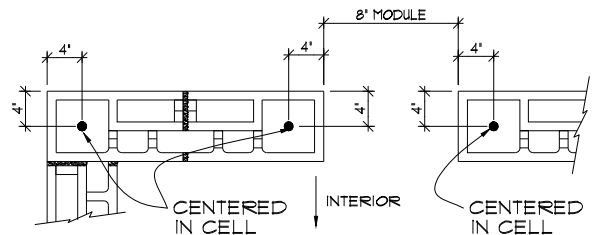

WINDOW / DOOR OPENINGS - 8"

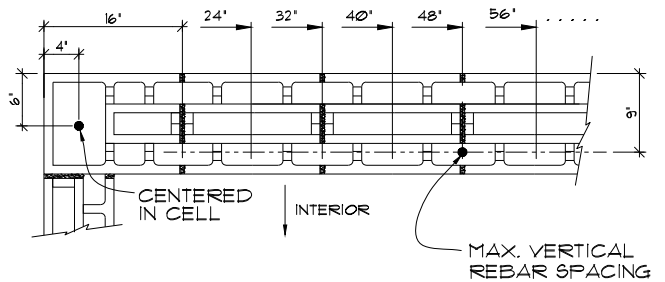

STANDARD WALL - 12"

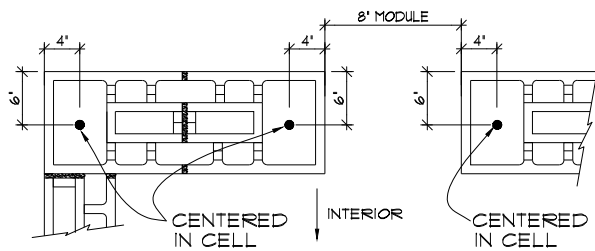

WINDOW / DOOR OPENINGS - 12"

Post-Tension or Monolithic Slabs

The structure's engineered details should be reviewed when these types of construction techniques are to be utilized. The vertical rebar placement remains critical and a shop drawing should still be supplied to the concrete sub contractor and strictly adhered to (or follow Figure 3 recommended guidelines).

Block Bond

When laying out the first course of Omni Block, the mason shall follow the standard block bond procedure as if the building was standard CMU.

Embed Notations

While block bonding the structure, make the notations on the slab for all electrical box placements, water line locations, HVAC lines, and any other embed that will affect the block wall.

Stacking Block

There is an exterior side and an interior side of the 8" Omni Block. Laborers should be instructed to stack the block with all of the exterior sides uniformly to the same side and perpendicular to the future block wall. Stacking the block so that the block are uniformly stacked avoids having to spin the block before laying it onto the mortar bed. This uniform strategy greatly improves masonry productivity.

There are left and right corners so three of each should be uniformly placed at all corners of a structure for each 4' lift. The corner block is also the window and door jamb block, so three of the appropriate jamb block and three half block should be placed at each door jamb. A similar strategy should be considered at each window opening.

## Notes

---



---



---



---

Figure 5

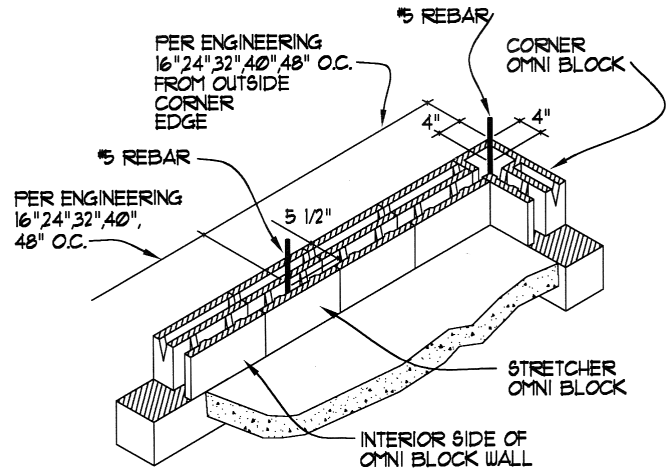

○ ISOMETRIC - 8" STEM

Figure 6

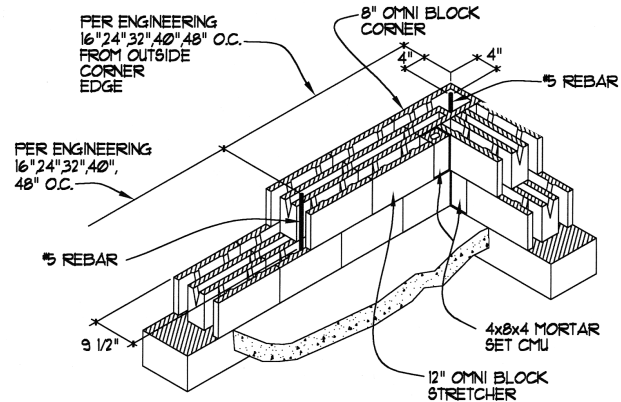

○ ISOMETRIC - 12" STEM

## Builder's Checklist

- ✓ Rebar sizing communicated to concrete sub.
- ✓ Verify that stem wall is 8" or 12" wide.
- ✓ Review rebar placement.
- ✓ If block stem is utilized, indicate to mason where grout voids will occur (see Plumbing and Electrical sections).

Plumbing

Plumbing locations must be determined prior to the masonry walls being erected. All plumbing can be accommodated within the block so no furring-out and drywalling is required. However, it is recommended to furr-out the wall where the kitchen sink, dishwasher, disposal, other electrical outlets and cabinetry are all located, if on an exterior wall.

Water Main

Local code shall dictate where the water riser should be located. See Figure 6 for ideal main water riser entrance through the block. If this is not possible, see Figure 10 and alternate corner block to create a hollow cavity within the block wall. This method can easily accommodate up to a 4" outside diameter water riser.

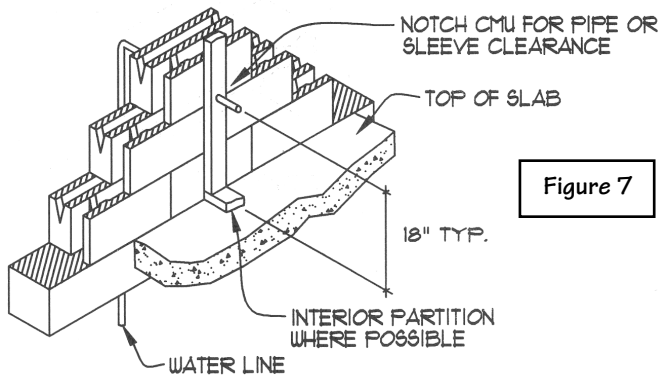

Figure 7

○ WATER RISER

Water Line - Waste Vent

Water lines on all exterior walls need to be stubbed up into the stem wall a minimum of 1 1/2 inches and a maximum of 3 1/2 inches from inside face of block (see Figure 8). Copper should always be protected with an alkali resistant material. These lines can be stubbed up anywhere in the exterior wall except in a vertical rebar and grout cell. Waste vent piping should stub 56" above top of stem to allow mason to lay block over the waste vent six courses (first grout lift) and leave approximately 8" of the stub to remain before coupling and extensions are required.

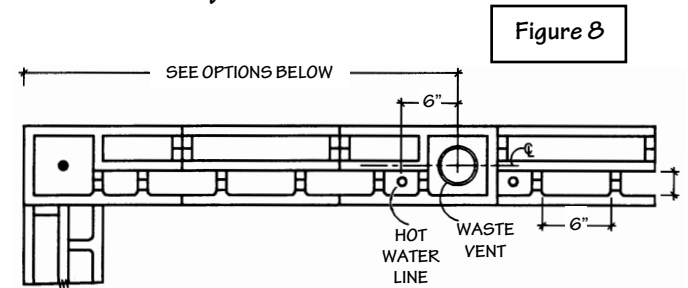

Figure 8

OPTIONAL WASTE VENT LOCATIONS:

- 1) ANY ODD FOOT (1'0", 3'0", 5'0"....)
- 2) ANY ODD FOOT PLUS 8" (1'8", 3'8", 5'8"....)
- 3) ANY EVEN FOOT PLUS 4" (2'4", 4'4", 6'4"....)

○ WATER LINE - WASTE VENT PLAN VIEW

Water Lines

All interior water lines should be roughed 90° out of the wall at 18" (bottom of the pipe). This allows the mason to lay two courses of block under the 90° without disturbing the copper pipe. The bottom of the third-course block is then appropriately notched, which enables the block to be laid over the pipe, without disturbance of the pipe.

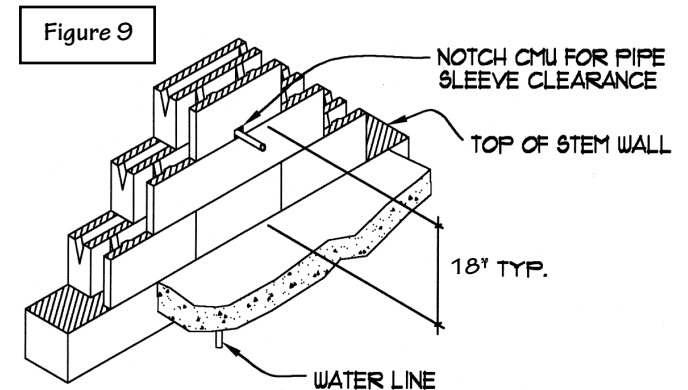

Figure 9

○ WATER LINE ROUGH-IN

Hose Bibbs

Hose bibbs should be roughed 90° out of the wall at interior partition wall locations where possible in order to secure the hose bibb.

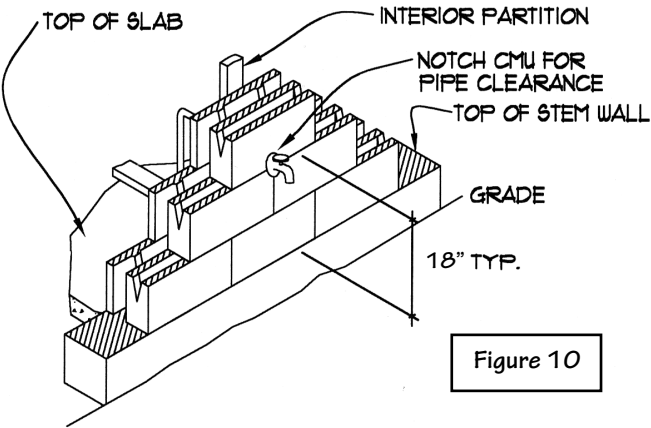

Figure 10

HOSE BIBB ROUGH-IN

Waste Vent Stacks

Omni Block's open celled corner blocks easily accommodate waste vents (see Figure 10). Proper location of the waste vent (see Figure 7) on an exterior wall is critical to avoid the plumber coming back to elbow the vent pipe into an open cell. Waste vents also need to be stubbed into the stem wall a minimum of 1 1/2 inches to clear the block face. The plumber should stub the waste vent 56" above the top of the stem.

When utilizing an Omni Block stem, the waste vent locations should be determined during stem installation. This allows the waste vent block cells to be void of grout. The plumber can then stub up the water lines and the waste vents.

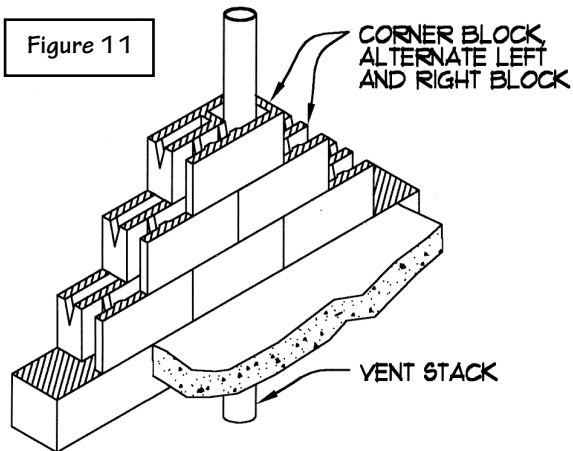

Figure 11

WASTE VENT ROUGH-IN

Access Panels

Spa tubs, steam showers, and other such items usually require access to the electrical and motoring mechanism. When access needs to be located through the block, a steel access panel is recommended. Consult the spa manufacturer's minimum access requirement for panel sizing. A 16" x 16" access panel is an ideal dimension when working with block. All panels should be on the job site so that the adjacent block can be tightly installed around the access panel (see Figure 12).

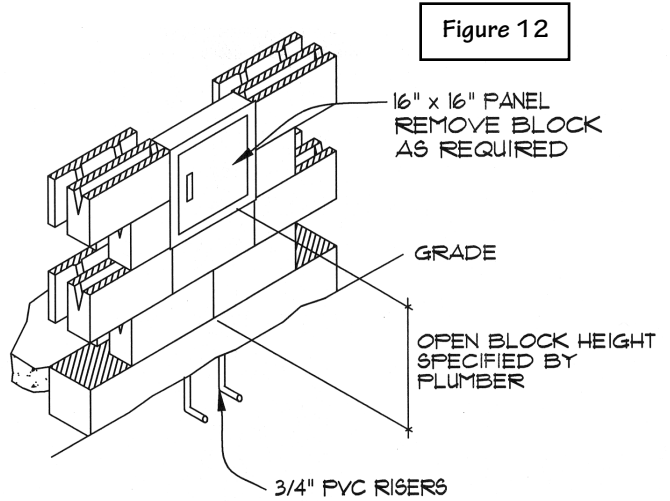

Figure 12

ACCESS PANEL

Dirty Arms

Local code shall dictate the placement and the appropriate fall for 'dirty arms'. All dirty arms must to be roughed out and capped at 90° from the masonry wall. The ideal height of the horizontal piping is 21" bottom of pipe.



## Fire Sprinklers

Many local code ordinances are requiring fire sprinkler protection. If required, it is strongly recommended that the fire sprinkler subcontractor is consulted for any particular requirements. Typically, the plumber needs to stub up in the wall copper pipe from the water riser (see Figure 13). This distance of 'unsupervised pipe' in the wall can be no more than 3'0" from the point it enters into the wall to the fire sprinkler check valve. An interior access panel is recommended (see Figure 12). The mason needs to know where the fire sprinkler main piping is to be ran in order to leave that block cell void of foam insulation.

If the square footage under roof is 4000 feet or greater, a Fire Department Connection (FDC) is required under most local codes. The FDC needs to be determined and communicated to the mason in order for a hollow cell to be provided. In addition, the FDC must be directly under the fire bell and the fire bell must be visible from the street and no more than 3' from the front of house. An electrical box is to be installed where the fire bell is to be positioned.

The above suggestions should be followed only after consulting the local code. Any local code variations should be followed.

Figure 13

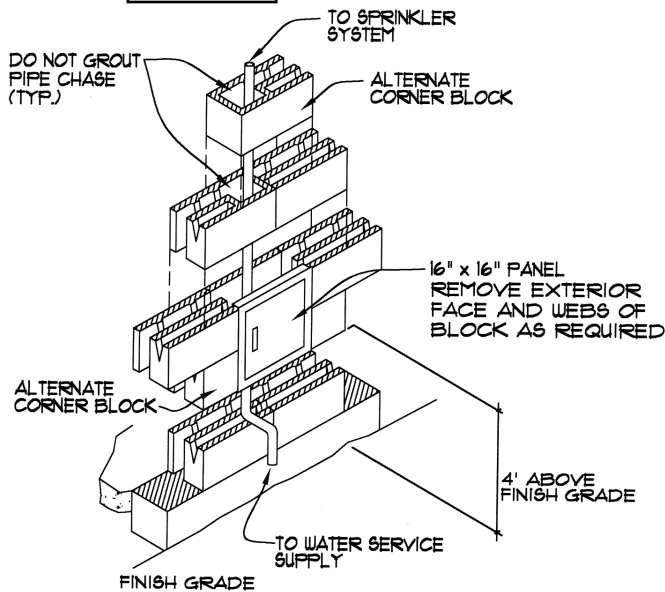

## FIRE SPRINKLER SYSTEM ROUGH-IN

## Sleeves

Sleeves should be installed in the block from the exterior to the interior to allow for future piping. Hot water pressure relief piping, HVAC freon lines, and other piping is achieved by the mason providing a 1 1/2" PVC sleeve through the block at a builder determined location (see Figure 14). This proactive installation process is much better and more economical than core-cutting or hammering the block and then patching.

Figure 14

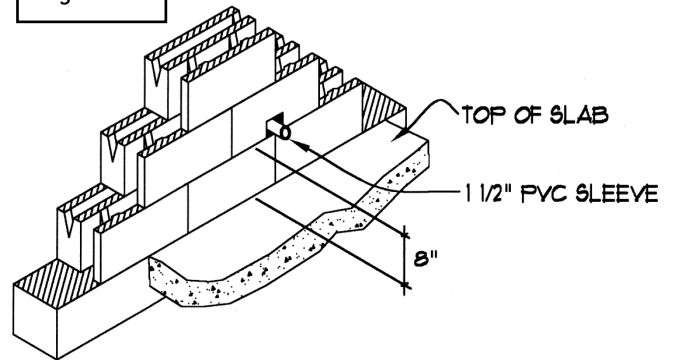

## HOT WATER PRESSURE RELIEF

## Gas Lines

Because of piping connection techniques and limitations, it is recommended to locate a 'planned' interior partition wall where the gas piping can be run later in the construction process vertically (see Figure 15). Another option is to find an inconspicuous area to furr-out that is large enough to house the gas piping. In either case, a sleeve (overall diameter to be determined by the plumber) through the masonry wall at the pre-determined location should be installed by the mason.

Figure 15

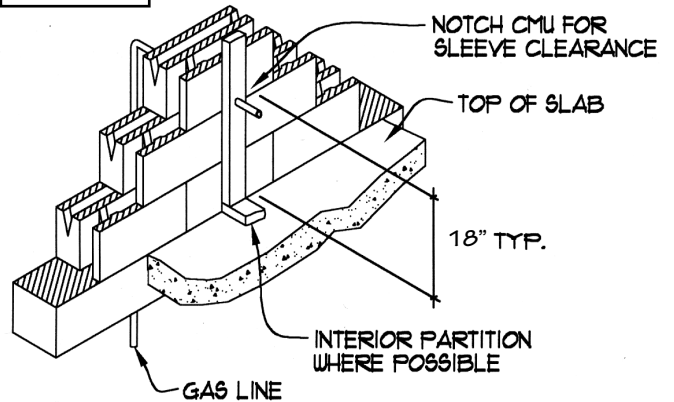

## GAS LINE ROUGH-IN

Freon Lines

Typical Freon and condensate line installation includes two sleeves (sizing specified by the HVAC contractor) protruding through the block wall (see Figure 15). Ideally, an applicable modification to Figure 14 allows for the lines to later run within interior partition walls. The least favorable option is to create a vertically open cell (see Figure 10). With this option, however, horizontal rebar may ultimately obstruct or impede the 'fishing' of the lines in an otherwise open cell.

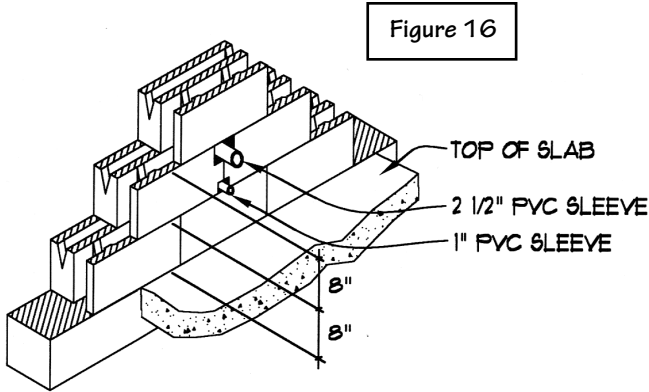

○ HVAC LINES

Dryer Vents

Venting the dryer to the exterior through the block wall is accomplished by the mason providing an open penetration, usually 5<sup>1/2</sup> inches wide by 8 inches high (see Figure 17). This penetration location is determined by the builder.

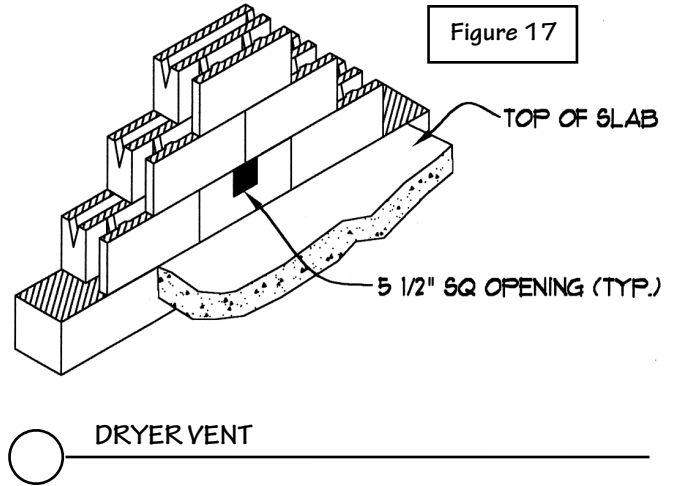

○ DRYER VENT

### Builder's Checklist

- √ Provide plumber with this manual prior to plumbing rough-in.
- √ Determine waste vent and water line locations.
- √ Determine location of water main riser.
- √ Determine location of gas main.
- √ Determine location of dryer vent.
- √ Determine location of hot water pressure relief line.
- √ Determine location of HVAC sleeves.
- √ Supply any access panels and specify location(s).
- √ Verify all of the above during the installation of the block.

## Notes

---



---



---



---



---



---



---



---



---



---

Electrical

Omni Block system installation interfaces a great deal with electrical requirements of a structure. Typically, the mason installs all the electrical and low voltage boxes and conduit within the block. This section is intended to outline the many options and, if adhered to, advantages of utilizing the Omni Block insulated concrete block system. The electrical placement requires some timely planning but will facilitate a quality finished product.

Ufer Wire

The electrician installs the Ufer wire per local building code. The Ufer will run within the block to the electrical main. The electrical main is usually about 40" from finished floor requiring approximately 6 feet of wire.

Low Voltage

Cable television, telephone, and landscape wiring can all be run from below grade, through stem, and up through the block to an access panel utilizing 3/4" PVC (see Figure 18). 3/4" 90° PVC sweeps are recommended. The cable and telephone main boxes are then located within the wall and all 'home-runs' are dropped or 'fished' down from the top of the block wall.

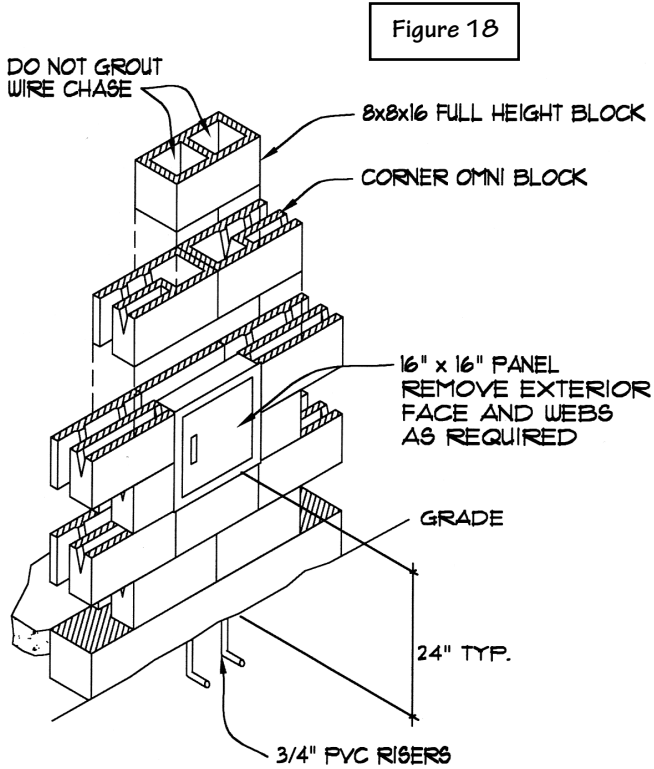

Figure 18

LOW VOLTAGE

Electrical Service Riser

Local code will dictate the height and location of the meter main panel or box. Figure 19 provides the typical electrical service riser block arrangement. Corner blocks are alternatively stacked with standard 8x8x16 CMU and left void of foam. A double chase is formed to accommodate electrical wiring running from above the top plate down the wall to the exterior opening created by removing the face and center web of a block. The local building code should be consulted to verify proper height location.

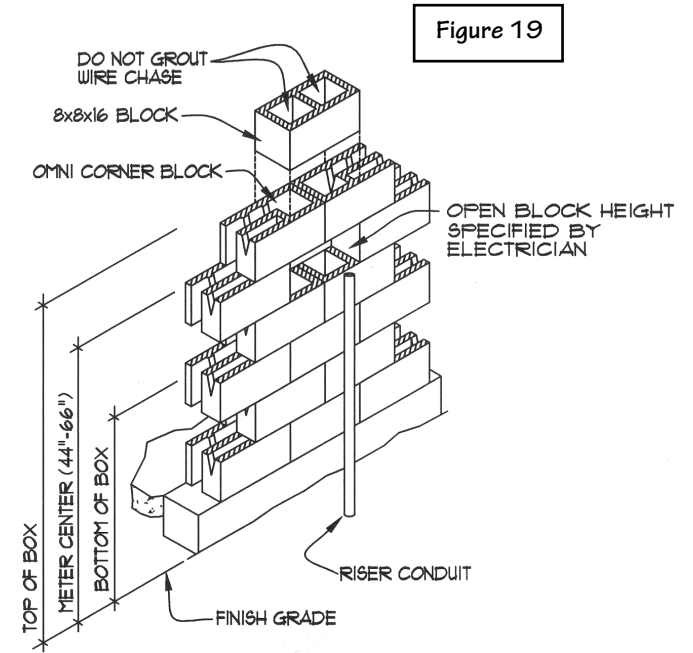

Figure 19

ELECTRICAL CHASE SCHEMATIC

Meter Main

The illustrations and details included in this manual detail a surface mounted service panel. A recessed panel is certainly feasible by adapting Figure 12 and allowing for the service riser to be housed within the block and stem wall. This option is more attractive from a security standpoint because the circuit breakers are normally on the interior of the structure rather than on the exterior.

Figure 20

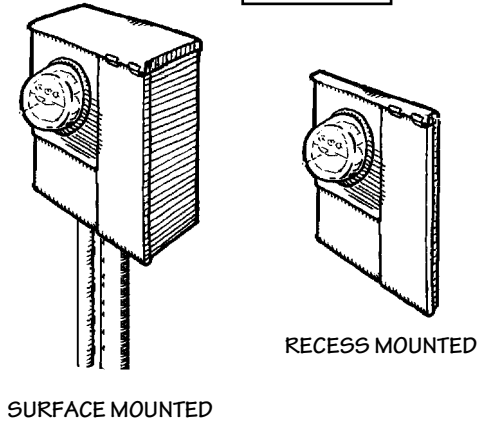

MAIN METER OPTIONS

Electrical Box Isometric

The illustration shown in Figure 21 depicts a typical 110V box along side a low voltage box and an exterior GFI box. The ideal situation is for the horizontal pipe to be 'swept' out of the block at interior partition wall locations utilizing 90° PVC sweeps, thus eliminating the need for vertical PVC.

Figure 21

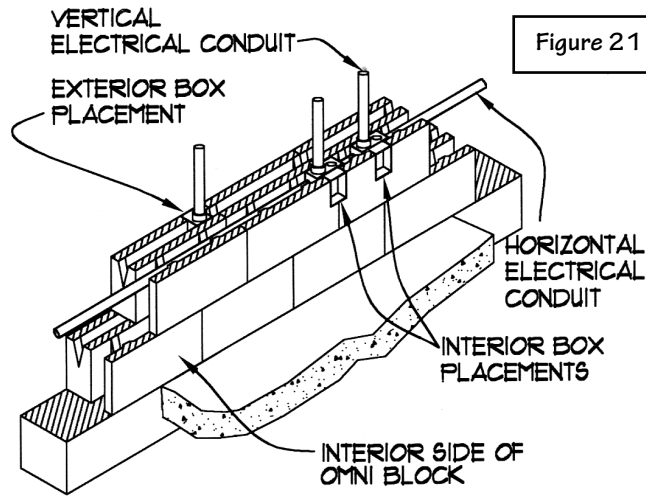

ELECTRICAL ISOMETRIC

Interior Electrical

The illustration shown in Figure 22 is a single gang box with a single vertical 3/4" PVC conduit. This is the typical installation for single gang electrical and low voltage boxes that are required on the interior side of the masonry wall. Numerous options are available and include:

- a) double conduit for 'in and out' switched wiring.
- b) double, triple or four-gang boxes.
- c) horizontal conduit running from box-to-box; minimizing vertical conduit requirements. Horizontal conduit initially takes a little longer to install but the more vertical conduit the mason can eliminate the quicker subsequent courses will take to install.

The interior box placement must occur in the center of the block, or when two block are butted together, centered on the butt joint. If the box is placed at a cross web, the above subsequent cross webs interfere with the vertical conduit.

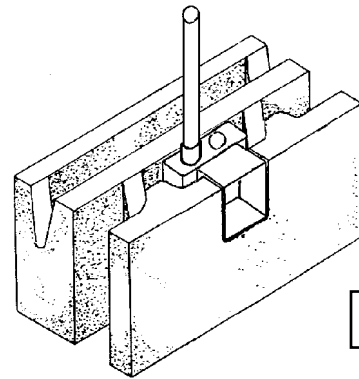

Figure 22

INTERIOR ELECTRICAL BOX

Surround Sound

All low voltage box requirements are placed into the block wall as depicted in Figures 21 and 22.

Security System

The pre-wire for the alarm system is best accomplished prior to any interior surface application. The mason 'scores' the block for the alarm/security subcontractor to run the security wire which is either caulked or glued into place. Magnets are then installed to windows and the other end is left coiled above the top of the wall for future connection.

Door Bell

A 3/4" PVC conduit is run vertically and swept out of the wall utilizing a 90° sweep. An electrical box is not necessary for a surface mounted door bell.

Exterior Electrical

The illustration shown in Figure 23 is a single gang box with a single vertical 3/4" PVC conduit. This is the typical installation for single gang electrical and low voltage boxes that are required on the exterior side of the masonry wall. Note: The exterior box placement must occur at either end of the block in order to avoid the conduit from hitting the webs in the block above.

Figure 23

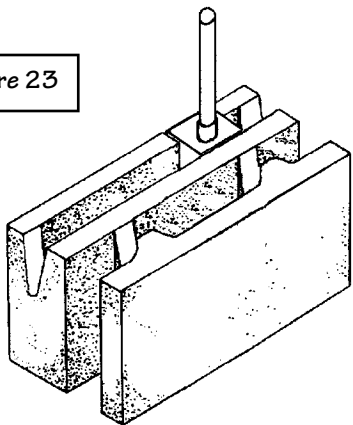

○ EXTERIOR ELECTRICAL BOX

Thermostat Wire

The thermostat wire is usually ran with the AC Freon line and does not need special consideration. Check with the HVAC contractor to verify this requirement. A separate electrical box and conduit can be installed, if requested.

Air Conditioner 220 Volt Line

A 1" PVC conduit with a 90° sweep is provided for the quick disconnect box. The HVAC or electrical contractor determines (per local code) height and location of this conduit. Most local codes also require a GFI 110V outlet within a specified distance of the air conditioner. The ideal situation is to locate exterior boxes where interior partition walls are to be erected. This allows for the horizontal conduits to be run into these walls which provides an easy access for the electrician and also eliminates the need for the mason to run vertical conduit.

Garage Electric Eye

Most codes require an electric eye for automatic garage door openers. A 90° sweep is attached to 3/4" PVC conduit and stubbed out at both interior sides of the garage door at 6 inches above finished garage floor. Low voltage wiring is 'fished' through the conduit by the electrician.

Electrical Parts

The mason usually supplies all the electrical boxes and conduit (not including panel or wiring) that are to be installed into the masonry wall. Jobs run smoother and more efficiently when the mason does not have to wait for the electrician to provide the electrical parts at the job site.

Omni Block typically stocks electrical boxes fabricated in variations that meet most all the specified electrical requirements described on building plans. Please refer to [www.omniblock.com](http://www.omniblock.com) for current price list and availability.

## Builder's Checklist

- ✓ Schedule a brief 'prior to the start of masonry' meeting at the job site with the electrical and low voltage subcontractors and the mason.
- ✓ Make sure all electrical switch and outlet requirements are indicated on the plan.
- ✓ Determine main incoming telephone feed location.
- ✓ Determine main incoming cable/TV feed location.
- ✓ Determine meter /main location.
- ✓ Determine all telephone, cable, sound, security, pool pump, pool light and door bell locations that occur on masonry walls.
- ✓ Determine all air conditioner locations and HVAC lines.
- ✓ Check into how the thermostat wiring is to be handled.
- ✓ Make sure electrician installs Ufer with enough footage to reach electrical main.

## Notes

---



---



---



---



---



---

Dimensions

Window and door width and height dimensions should be on an 8" design module (see chart below). Windows and door openings that are not listed below will require cutting of the block. The amount of cutting is determined by these variables; how large of an opening, and whether it is the width, or the height that is not in 8" block dimension. The width dimension is more critical than the height.

Only three combinations of numbers work for an 8" block module design:

- any even number: 2<sup>0</sup>, 4<sup>0</sup>, 6<sup>0</sup>, 8<sup>0</sup>...
- any even number plus 8": 2<sup>8</sup>, 4<sup>8</sup>, 6<sup>8</sup>, 8<sup>8</sup>...
- any odd number plus 4": 1<sup>4</sup>, 3<sup>4</sup>, 5<sup>4</sup>, 7<sup>4</sup>...

WIDTH OPTIONS	
	1 <sup>4</sup> 2 <sup>0</sup> 2 <sup>8</sup> 3 <sup>4</sup> 4 <sup>0</sup> 4 <sup>8</sup> 5 <sup>4</sup> 6 <sup>0</sup> 6 <sup>8</sup> 7 <sup>4</sup> 8 <sup>0</sup>
HEIGHT OPTIONS	1 <sup>4</sup>
	2 <sup>0</sup>
	2 <sup>8</sup>
	3 <sup>4</sup>
	4 <sup>0</sup>
	4 <sup>8</sup>
	5 <sup>4</sup>
	6 <sup>0</sup>
	6 <sup>8</sup>
	7 <sup>4</sup>
8 <sup>0</sup>	

The opening can be any of these combinations and will not require any cuts in the block.

Aluminum / Vinyl Windows and Doors

Actual frame-to-frame window/door dimensions should be 1/2" under rough opening size, which is standard sizing for most aluminum and vinyl window/door manufacturers. The window/door installer most often attaches the window/door by using Tapcon (or equal) screws at the window/door jambs. The undersizing of the window/door allows for the window/door installer to place plumbing shims adjacent to the window/ jamb before attaching the window/door. Many builders wrap the jambs with a waterproofing material before the window/door installation. The windows and doors are installed per manufacturer's instructions. This procedure is exactly the same as standard CMU.

Wood Window and Doors

Actual frame-to-frame window/door dimensions should be 3 1/2" under rough opening size. This under sizing allows for a wood buck to be installed to each jamb with Tapcon (or equal) or masonry "red-heads" before the window/door is installed. The additional undersizing of the window/door allows for the window/door installer to place plumbing shims adjacent to the window/ jamb before attaching the window/door. Many builders wrap the jambs with a waterproofing material before the window/door installation. The window and doors are installed per manufacturer's instructions. The entire process is exactly the same as standard CMU.

Figure 24

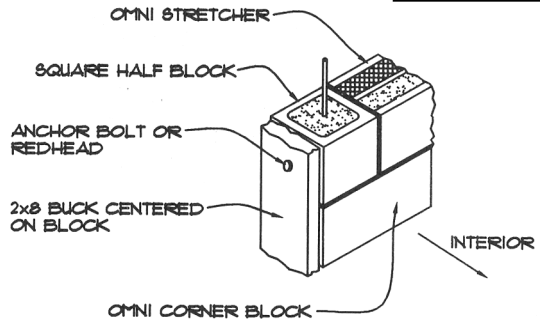

○ WINDOW / DOOR BUCK AT JAMBS

Typical Window / Door Jamb

Window and door jambs are created using Omni corner block and 8x8x8 standard CMU block. Jambs contain vertical rebar as specified by the engineer and are solid grouted.

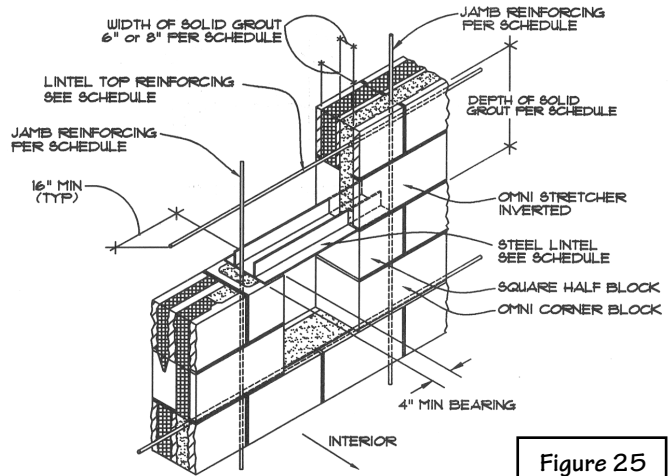

Figure 25

○ WINDOW / DOOR JAMB DETAIL

Lintel Details

The illustration shown in Figure 26 is a typical block lintel detail except that a Powers Steel lintel is recommended. The standard configuration is that of an upside down "double T". The rails of the "double T" are spaced so that when an Omni stretcher block is inverted, the web constrictions ride over them, making this type of lintel ideal.

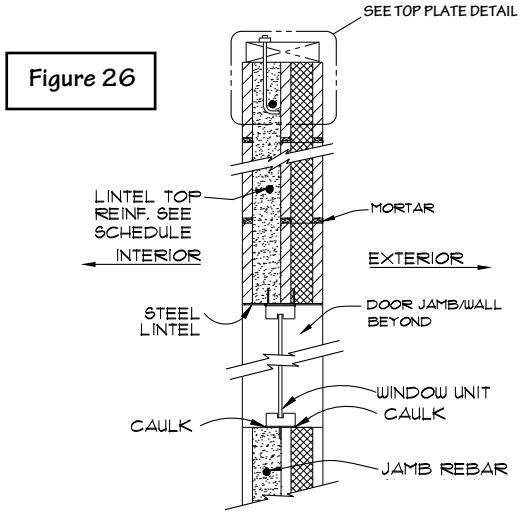

Figure 26  
LINTEL DETAIL - 8"

Top Plate

The mason provides and installs 'J' bolts per engineering. These act as the anchor bolts for the top plate (see Figure 28). The framer installs and bolts the top plate (usually 2 x 8) to the block the same as if it were regular block. The framer also must drill the top plate for the electrical conduit and any waste vents that are stubbed above the block. The top plate should be flush with the outside edge of the block which allows for 1/2" drywall to later be applied on the interior side of the top plate.

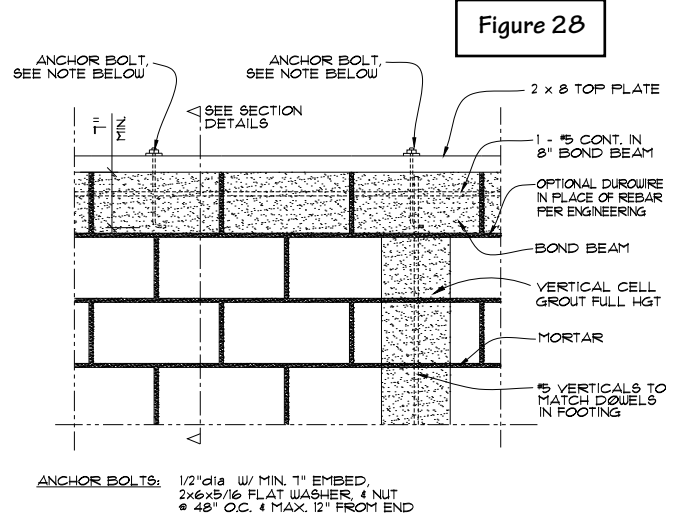

Figure 28  
TOP PLATE DETAIL

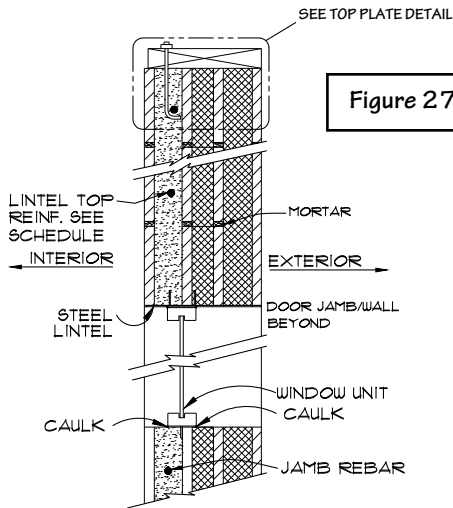

Figure 27  
LINTEL DETAIL - 12"

## Builder's Checklist

- ✓ During design, make sure all window and door openings are block module, if possible.
- ✓ Order aluminum or vinyl windows and doors 1/2" under rough opening.
- ✓ Order wood windows and doors 4" under rough opening.
- ✓ Communicate the rough opening widths and heights to the mason.

## Notes

---



---



---

## Bond Beam

Every Omni stretcher block is in effect a bond beam block. When engineering specifies a mid wall bond beam, the mason must leave the interior cores void of foam, place specified horizontal rebar, and solid grout the interior cores. In lieu of mid wall bond beams, some engineers allow that Duowire be placed in the bed of mortar every other course of block.

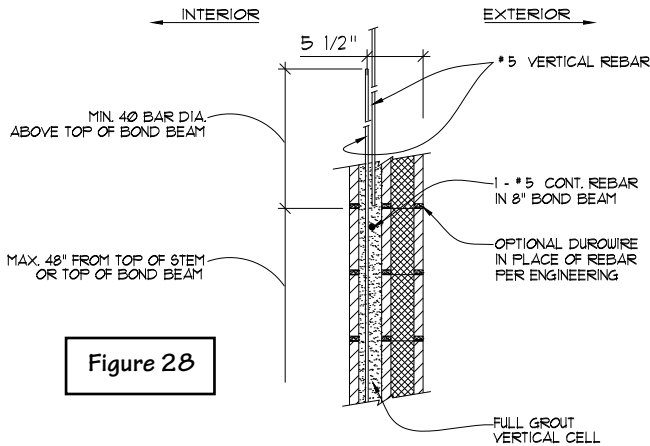

Figure 28

### BOND BEAM - MID WALL

## Trusses

The trusses are erected and secured the same as with standard masonry.

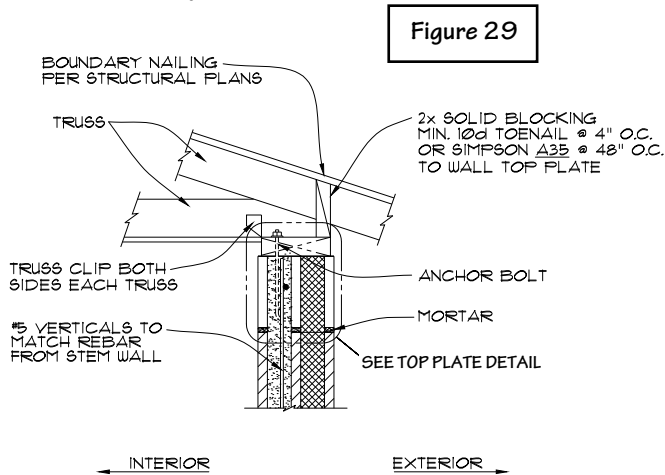

Figure 29

### BOND BEAM - WITH ROOF TRUSS & EAVE

## Wood Parapets

The builder should consult with the stucco contractor regarding the set-back distance of the wood parapet from the outside edge of the block. This distance can vary according to what the builder and/or stucco contractor decides to use as a substrate and what the desired finish is to be.

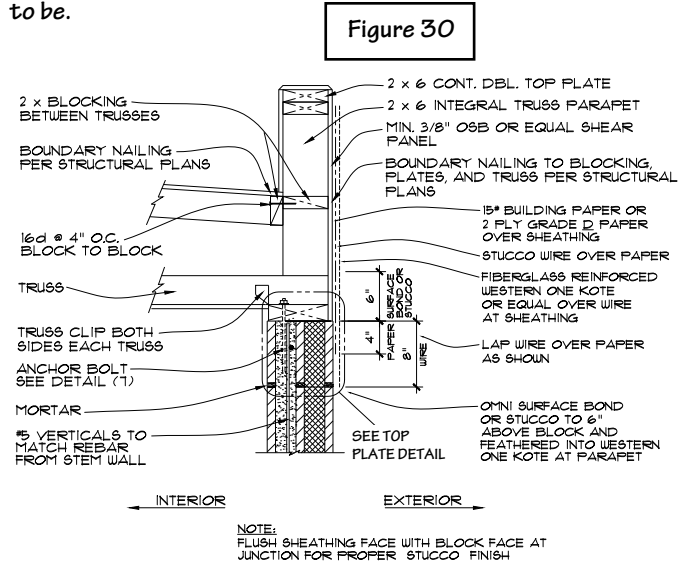

Figure 30

### BOND BEAM - WITH ROOF TRUSS PARAPET

## Ledger

Multi-story buildings, masonry parapet conditions, or exterior decks mandate a ledger to be bolted to the block wall. Figure 31 provides typical ledger construction methodology. The area use (attic or second story) above the ledger will determine whether Omni Block or regular uninsulated CMU is to be utilized. The size of the ledger and ledger bolts is specified by a structural engineer.

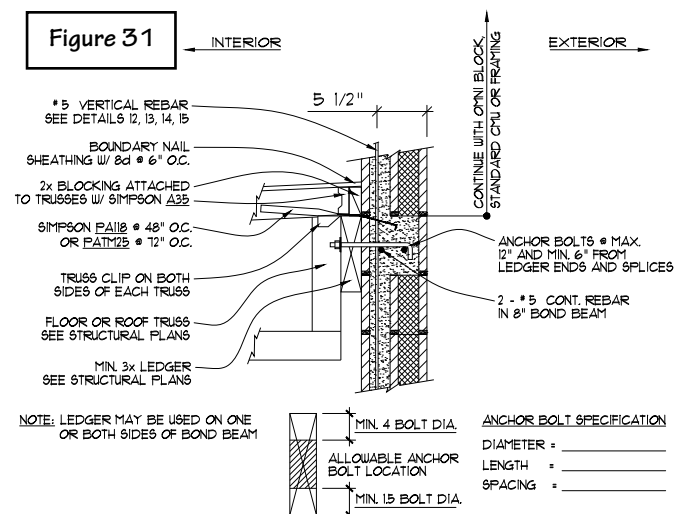

Figure 31

### LOAD BEARING LEDGER



## Beam Seats

The mason installs the beam seats per engineering. The builder should require the framer to specify all actual beam seat heights (during block construction). Some plans are vague when it comes to beam seat heights and location so extra precaution should be exercised. This is an interfacing item between the mason and the framer. Make sure only one of them has the beam seats in their bid.

Figure 32

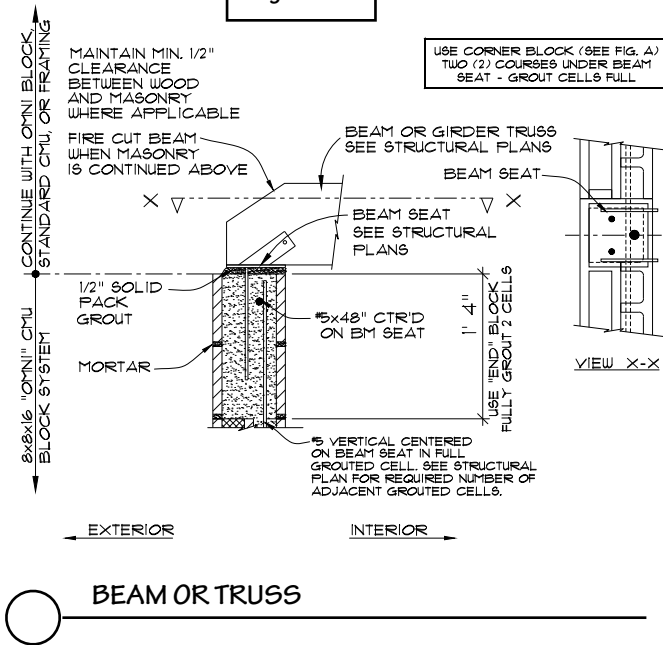

## Interior Partition Walls

Attaching interior partition walls to Omni Block can be accomplished in a number of ways. The most popular and effective method is to 'red head' or shoot nails into the block. This firmly attaches the stud to the block. It is strongly recommended to abundantly glue (construction grade) the stud to the wall during this type of attachment. This practically eliminates any movement of the stud wall away from the block wall which aids in preventing any future drywall cracking at this wood-to-block joint.

Other methods include 'J' bolts provided for by the mason during block construction. This method greatly reduces the flexibility of relocating an interior partition wall during the framing stage of construction. Another method utilizes masonry 'cut nails'. In either case, construction adhesive is strongly recommended.

The framer must allow for the thickness of drywall when attaching the wood (or metal) to the block because the block is not furred out (see Figure 33). This seam, after drywall, tape and texture should be flush and unnoticeable.

Figure 33

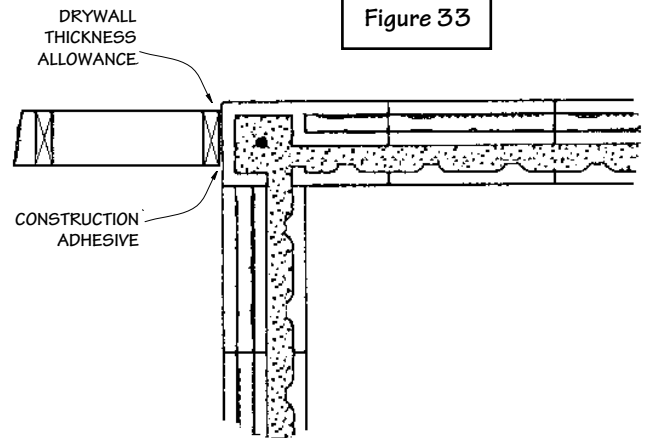

## Builder's Checklist

- ✓ Confirm that framer understands that the block is not furred out and allowance for drywall thickness is required.
- ✓ Make sure that the framer glues all partition stud material to the block with construction adhesive before attaching.
- ✓ Communicate with the framer and mason to determine all beam seat set heights and locations.
- ✓ If parapet tails are called for, discuss set-back distance with stucco contractor and then communicate result to the framer and truss supplier.
- ✓ Review ledger sizing and required height with framer and communicate that result to the mason.
- ✓ Confirm that the framer knows to accommodate protruding conduit above the top plate.

## Notes

---



---



---

## Interior Finishes

Itemized below are the methods of finishing the interior of a structure.

### Drywall Appearance

The most common finish over the block is a drywall appearance that matches interior partition drywall after it has been 'taped and textured'. In order to accomplish this look and obtain a seamless transition between interior partition walls and Omni Block, three options are available.

#### Option 1: Surface Bond

The interior block surface is coated with a surface bonding material (Omni Bond; see surface bonding section, pg. 19 & 20) that is applied one-eighth inch to one-quarter inch thick in a semi-smooth texture over the block before any interior framing is started. Surface bond has the appearance of stucco but is much stronger. It not only bonds extremely well with the block but bonds exceptionally well with regular construction drywall compound. It also makes the mortar joints disappear. At the drywall stage of construction, the drywall contractor tapes block-to-drywall joints the same as he would if it were drywall-to-drywall. A skim coat is then applied over the surface bond followed by a texture coat, which is the same texture coat that is applied over the interior drywall.

#### Option 2: Drywall Compound Only

Many builders eliminate the surface bond coat and have the drywaller apply drywall compound directly onto the block. There has been no appreciable performance difference between this method and Option 1 above and there is a considerable cost savings.

#### Option 3: Laminated Drywall

The least preferred method is laminating the interior block surface with drywall. This method partially diminishes the exposed thermal mass effect of the block wall. If used, standard construction adhesive is applied to the back of the drywall and set onto the block wall face. A few screws may be utilized to fasten the drywall to the block wall until construction adhesive has dried.

### Top Plate Coverage

The interior exposed top plate (above the block) can be covered several ways. The recommended method is to attach 1 1/2" wide by 1/2" thick drywall strips to the top plate. The wall seam and ceiling seam can then be taped with whatever the drywaller prefers (paper or fiberglass). Some drywallers have found that 'hot mud' in this area works well.

## Corner Bead

All window and door openings require the use of square or bull nose corner bead. It is recommended to coat the inside bead with drywall compound and set around the opening. The corner bead edging is then feathered onto the surface bonded or laminated drywall wall and opening return with drywall compound. The surface bond coat is not intended to be the finish around openings. For proper interior finish, corner bead must be used.

## Paint

All interior block drywall treated (Option 1, 2, or 3) surfaces are primed and painted to match all other interior drywalled partition walls.

Block left exposed can be painted. A masonry primer should be used before the finish paint is applied.

## Repairs

Small holes created in drywall appearance walls by Tapcon screws (or equal), plastic or lead inserts with tapping screws, are patched with regular drywall compound. Since the block face is a little over one inch thick and holes are small, patching is accomplished easier than repairing typical drywall that is only half of an inch thick.

## Exposed Block

Omni Block can be manufactured in a variety of integral colors, architectural finishes (scored, scored split, foundered, or burnished) as well as the locally produced standard gray. Any of these appearances may be the actual finish.

## Sealers

The application of a concrete sealer over the exposed block will yield more of a sheen or glaze appearance. Sealers penetrate the block which makes it more stain and moisture resistant while locking-in the calcium (white residue sometimes seen on exposed block) that can cause efflorescence.

## Stains

Penetrating colored stains are another finish option over exposed block. Penetrating stains applied on the exposed block after the block walls have been constructed will yield a uniform colorization on the block as well as the mortar. The combination of a sealer and stain can be applied during the same application.

## Exterior Finishes

Itemized below are the methods of finishing the exterior of a structure.

### Exposed Block

Omni Block can be manufactured in a variety of integral colors, architectural finishes (scored, scored split, foundered, or burnished) as well as the locally produced standard gray. Any of these appearances may be the actual exterior finish.

### Sealers

The application of a concrete sealer over the exposed block will yield more of a sheen or glaze appearance. Sealers penetrate the block which makes it more stain and moisture resistant while locking-in the calcium (white residue sometimes seen on exposed block) that can cause efflorescence.

### Stains

Penetrating colored stains are another finish option over exposed block. Penetrating stains applied on the exposed block after the block walls have been constructed will yield a uniform colorization on the block as well as the mortar. The combination of a sealer and stain can be applied during the same application.

### Paint

Block left exposed can be painted. A masonry primer should be used before the finish paint is applied.

### Stucco

Omni Block is stuccoed in the same manner that standard CMU is stuccoed. Consult local stucco contractors for the regionally preferred procedure.

### Integral Synthetic Stucco

There are numerous integrally colored synthetic stucco products on the market. Most, if not all, work very well over a base coat or scratch coat of stucco. Usually, these products are ultra violet (UV) stable and therefore provide long-lasting beauty.

## Surface Bond (OPTIONAL)

It cannot be over emphasized that the surface bond is optional, which means that it is NOT REQUIRED.

### Surface Bond Material

The surface bond (Omni Bond) is a Portland cement based, fiber reinforced pre-mixed (only add water) compound. It also contains epoxies, waterproofing agents, dehydrators and Silica sand. It is applied via trowel. Its consistency should be almost that of peanut butter. Too much water in the mix facilitates shrinkage cracking during the curing process. It is listed as a water resistant material and is much stronger than regular stucco, but it can still crack. Depending upon the ambient outside temperature, its workability is approximately 45 minutes. Coverage is approximately 25 to 30 square feet per 50 lb. bag. Omni Bond is available from Omni Block.

### Surface Bond Preparation

Prior to applying the surface bond cement, the walls should be wetted thoroughly but not soaked. This wetting of the block and keeping the block damp while applying the surface bonding cement is very important (see Figure 34). Dry block will suck the moisture out of the surface bonding cement causing a loss in bonding strength. In very dry climates or where warm winds are prevalent during application, this wetting process may have to be repeated during application to assure proper adhesion and strength.

Figure 34

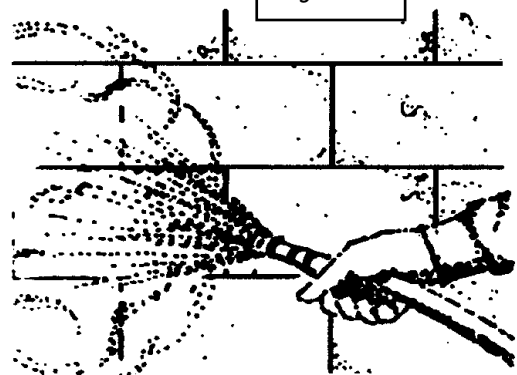

MIST APPLICATION

Surface Bond Application

Apply the surface bonding cement only when the weather is above 40°F and insure that the surface is maintained above this temperature for at least 24 hours after application. The surface bonding cement is applied and easily worked with an ordinary plasterer's trowel. The surface bond should be applied to a minimum thickness of 1/8" using upwardly sweeping diagonal strokes (see Figure 35).

All block and joints should be covered evenly. Excessive troweling should be avoided as it causes the fiber to come to the surface, which affects the curing process and ultimate strength of the surface bond. If for any reason the application is interrupted, stop at a natural break point, such as a corner, door, or window opening.

The interior surface bond is to be applied in a semi-smooth to smooth finish immediately after the block is erected and just prior to the framing stage of construction.

The exterior surface bond can be applied as a first coat or 'brown coat' prior to an unlimited array of finishes using steel, rubber, wooden or sponge trowels that can create different textures over the surface bond. These finishes can be regular stucco then painted or synthetic integral colored stucco.

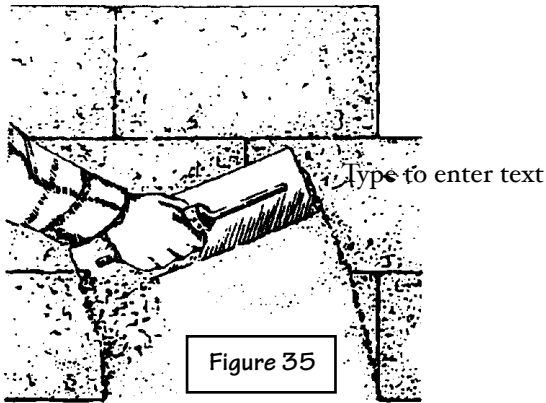

○ SURFACE BOND APPLICATION

Surface Bond Curing

The surface bonding cement takes its initial set within one to two hours and will gain much of its ultimate strength within 24 hours of application. To insure maximum performance and proper dehydration, the surface of the bonded wall should be misted regularly within the first 24 hours after application and within 48 hours in dry or windy climactic conditions. Keep the surface bond from freezing for the first 48 hours after application.

# Builder's Checklist

- ✓ Determine whether interior is to be surface bonded, skim-coated, or laminated with drywall.
- ✓ If the wall is to be surface bonded, plan to do it immediately after the block construction is completed and before any interior framing is started.
- ✓ Verify that the surface bond applicator understands the surface bond preparation directions.
- ✓ Depending upon ambient air temperature and humidity, plan to periodically lightly mist the surface bonded walls for up to 24 hours after application.
- ✓ Verify that the drywall subcontractor includes the following in his bid:
  - 1) top plate coverage
  - 2) corner bead for all openings
  - 3) skim coat and texture coats
- ✓ Inspect job site as drywaller is applying corner bead to verify that it is being installed evenly and squarely.
- ✓ Determine whether the exterior is to be surface bonded and what finish is desired.
- ✓ It is advised that surface bond be applied to all wood areas after a scratch coat of stucco is first applied.

## Notes

---



---



---



---



---



---



---



---



---



---

## PRE-CONSTRUCTION / START-UP

### PLUMBING

- Water main location
- Water lines
- Hose bibbs
- Gas line sleeves (main, fireplace)
- Hot water heater relief valve sleeve
- Waste vents

### FIRE SPRINKLER

- Fire sprinkler panel
- Fire bell

### ENGINEERING

- Beam pocket locations and heights
- Ledger bolt sizing, heights, and frequency
- Top of wall anchor bolt sizing and frequency
- Expansion joint(s)

### ELECTRICAL

- Phone / cable outlets
- 110 outlets
- Switches
- Exterior 110 outlets
- Exterior switches
- Exterior light boxes
- Garage door safety eyes
- Door bell
- Garbage disposal switch/outlet
- HVAC power and 110 GFI
- Electrical panel / Ufer wire / cell or sleeve
- Low voltage panels (irrigation, cable, phone)
- Sound system boxes and conduit
- Christmas outlets

### SECURITY

- Score wall for operational windows and doors
- Motion detector boxes

### OTHER

- Window and door locations
- Window and door rough widths and heights

### HVAC

- Freon line cell or sleeve
- Dryer vent cell or sleeve
- Return vents

This start-up sheet is an invaluable tool intended to assist the various trades that interface with Omni Block. Typically, at a pre-construction meeting, the mason requests from the other sub-contractors their needs and communicates to them how he plans to address them. This meeting 'of the minds' is critical and greatly improves the overall continuity of construction.

## OMNI BLOCK CONSTRUCTION FLOWCHART

	Design	Footings/Stem	Pre-Slab
<b>Concrete</b>	<input type="checkbox"/> Have engineer, architect, or designer create 'shop drawing' detailing rebar placement.	<input type="checkbox"/> Rebar sizing communicated to concrete sub. <input type="checkbox"/> Remind concrete sub stem wall is 8" or 12". <input type="checkbox"/> Review rebar placement and emphasize its importance. <input type="checkbox"/> Indicate to concrete sub where block outs are to occur (see Plumbing and Electrical).	
<b>Plumbing</b>	<input type="checkbox"/> Determine location of gas meter. Try and locate main feeder at an interior partition wall location so that it may be ran vertically in the interior partition wall. <input type="checkbox"/> Determine location of water riser (same as above).	<input type="checkbox"/> Determine location of waste vents in block walls and provide 'block outs' in stem.	<input type="checkbox"/> Remind plumber that waste vents must hit corner block cells in order to avoid coming back and elbowing vertical risers (see Omni Block Detail Sheet). <input type="checkbox"/> Verify proper waste vent locations.
<b>Electrical</b>	<input type="checkbox"/> Verify that all electrical switch and outlet requirements are indicated on the plan. <input type="checkbox"/> Verify that all low voltage (telephone, cable, sound, security, and door bell boxes are indicated on the plan.	<input type="checkbox"/> Determine and position where conduit needs to be placed for cable/TV, telephone, landscape and pool (ran within stem). <input type="checkbox"/> Have electrician supply steel conduit for riser and specify its location and height requirement. <input type="checkbox"/> Verify that electrician installs Ufer long enough to reach electrical main.	
<b>HVAC</b>			
<b>Windows Doors</b>	<input type="checkbox"/> Make sure all window and door openings are block module, if possible (see chart on pg 14).		
<b>Framing</b>	<input type="checkbox"/> Verify all beam seat locations and heights on plan. <input type="checkbox"/> Verify all masonry finished wall heights on plan.		
<b>Drywall</b>	<input type="checkbox"/> Make sure that top plate coverage, corner bead for all openings, skim coat and texture coat is in drywallers bid.		
<b>Optional Surface Bond or Stucco</b>			

## OMNI BLOCK CONSTRUCTION FLOWCHART

	Start of Masonry	During Masonry	Post Masonry
<b>Concrete</b>	<input type="checkbox"/> Schedule brief 'prior to the start of masonry' meetings at the job site with the electrical, HVAC, fire sprinkler, plumber, sound, security subcontractors and the mason.		
<b>Plumbing</b>	<input type="checkbox"/> Have plumber rough-out (90°) all water lines and waste vents . <input type="checkbox"/> Supply any access panels and specify their location. <input type="checkbox"/> Require fire sprinkler sub to meet with mason for fire sprinkler installation coordination.	<input type="checkbox"/> Verify fire sprinkler installation. <input type="checkbox"/> Verify access panel installation. <input type="checkbox"/> Verify all required sleeving has been installed.	
<b>Electrical</b>	<input type="checkbox"/> Determine main incoming telephone feed and cable/TV location and provide box or panel. <input type="checkbox"/> Determine meter /main location.	<input type="checkbox"/> Prior to 4 ft. grout, make sure all electrical and low voltage boxes are installed. <input type="checkbox"/> Schedule security sub to pre-wire exterior walls prior to interior surface bonding. <input type="checkbox"/> Verify main meter location. <input type="checkbox"/> Verify garage electric eye installation.	
<b>HVAC</b>	<input type="checkbox"/> Determine all air conditioner locations, HVAC line locations and how the thermostat wiring is to be handled.	<input type="checkbox"/> Verify dryer vent opening has been installed. <input type="checkbox"/> Verify HVAC line sleeve installation.	
<b>Windows Doors</b>	<input type="checkbox"/> Communicate to mason door and/or slider widths and heights so proper rough opening can be provided.		<input type="checkbox"/> During installation, make sure window will be centered in opening or a satisfactory plan is reached with the interior and exterior finishes in mind (see also Drywall, Framing and Stucco sections).
<b>Framing</b>		<input type="checkbox"/> Communicate to the framer and the mason that they need to agree on beam seat heights and locations.	<input type="checkbox"/> Verify that framer understands that the block is not furred out and that he needs to allow for the specified drywall thickness. <input type="checkbox"/> Verify that the framer glues all partition stud material to the block. <input type="checkbox"/> If parapet truss tails are to be used, discuss set-back distance with stucco contractor and then communicate that result to the truss supplier and the framer.
<b>Drywall</b>			<input type="checkbox"/> Inspect job site as drywall contractor is applying corner bead to make sure that it is being installed evenly and squarely.
<b>Optional Surface Bond or Stucco</b>		<input type="checkbox"/> Plan for interior surface bonding (optional) immediately following the block construction before any framing is done. <input type="checkbox"/> Have mason score block for security wire prior to interior surface bonding.	<input type="checkbox"/> Verify that applicator understands the surface bond preparation and application directions. <input type="checkbox"/> Communicate to the applicator the desired trim detail around windows; most notably the return (sill) and corner edging. <input type="checkbox"/> Advise the applicator of all wood frame areas that need prepared for a regular brown coat before surface bond, regular stucco or synthetic stucco application.

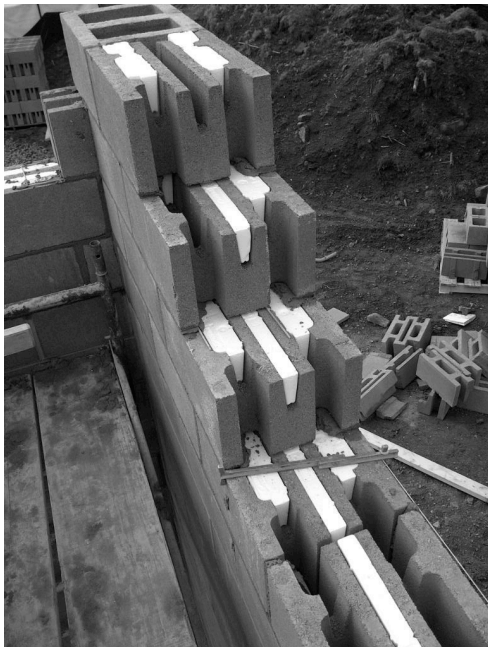

**Omni Block**  
AN INSULATED CONCRETE BLOCK

[www.omniblock.com](http://www.omniblock.com)